

Rotary tip cleaner

The new tip cleaner **FT-710** assists optimal cleaning!
It solves such problems as splashing
of solder and oxidation of tips.

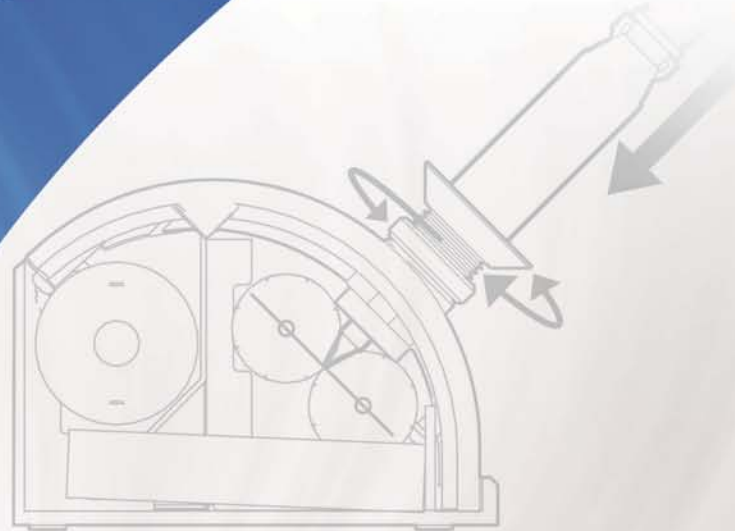

- Prevents solder from splashing
- Compatible with various HAKKO soldering irons and tips
- Controls the amount of solder to be left on tips
- Minimizes the drop of tip temperature
- Easy to maintain
- ESD safe
(A ground wire is not included)
- Silent design
- Energy-saving specification with only 5W power consumption
(AC adapter type)

■ Combines the best properties of a cleaning sponge and cleaning wire (HAKKO 599B).

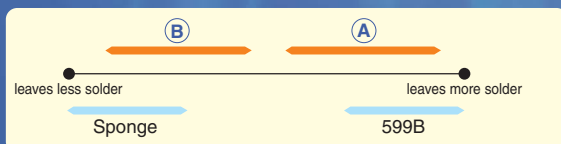

* (A): FT-710 with cleaning brush <A>
(B): FT-710 with cleaning brush

Solder-splashing prevention

The encapsulated design prevents solder from splashing during tip cleaning, which could become a significant cause of failure.

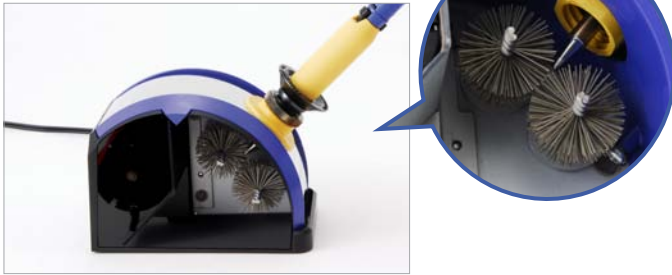

Because the housing is encapsulated, solder does not splash.

Controllable degree of solder removal

Two types of cleaning brushes are available. Selection of brushes can control the amount of solder to be left.

Brush	Cleaning brush A (Standard accessory)	Cleaning brush B (Optional)
Material	Resin 	Metal 
Image after cleaning	Solder slightly remains 	Solder is fully removed 
Benefit	Prevents tip from being oxidized and extends service life of tip	Suitable for soldering to a tiny section which requires control of solder amount

Packing List

● HAKKO FT-710 (With cleaning brush A and solder waste collector)	1	● AC adapter	1
● Receptacle (No.B3517, B3518)	2	● Gauge	1
● Lock nut	1		

Specifications

● HAKKO FT-710

Model Name	HAKKO FT-710
Motor Rating	DC24V 50mA
Power Consumption	5W
Standby Power Consumption	0.6W
Dimensions	71(W) x 77(H) x 107(D)mm
Weight	450g
Brush Rotational Speed	2500rpm

● AC adapter

Rating	DC24V 130mA
Dimensions	45(W) x 40(H) x 65(D)mm
Weight	0.25kg

Compatible with various HAKKO soldering irons and tips

A suitable receptacle can be selected and the height can be adjusted according to the soldering iron and tip to be used.

● Applicable table

Applicable tip	Receptacle A	Receptacle B	Receptacle C
T12, T15, T11	○		
T18, 900M, T14		○	
T10, T20, T13, T17			○

*This cleaner cannot be used for shape of 0.2JL, quad type, tunnel type, spatula type of the T12/T15 series.

*There are some tips with dimensions that cannot be adjusted with the standard receptacles.

In this case, please consult with your nearby dealer or distributor.

Slight drop of tip temperature

The water-free type minimizes drop of tip temperature when cleaning the tip and obtains high workability.

Easy to maintain

- The metallic waste collector enables you to clean easily. In addition, the driving parts are isolated from other parts, which prevents solder waste from entering.



Remove the plug of the adapter.

Hold the cover and remove it from the base.

Pick up the waste collector from the base and throw away solder accumulated on the waste collector.

- No tool required to replace cleaning brushes. Attachable & detachable with one-touch operation.

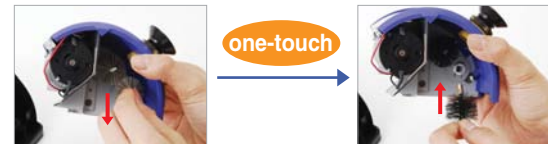

Packing List

● HAKKO FT-710 (With cleaning brush A and solder waste collector)	1	● AC adapter	1
● Receptacle (No.B3517, B3518)	2	● Gauge	1
● Lock nut	1		

Specifications

● HAKKO FT-710

Model Name	HAKKO FT-710
Motor Rating	DC24V 50mA
Power Consumption	5W
Standby Power Consumption	0.6W
Dimensions	71(W) x 77(H) x 107(D)mm
Weight	450g
Brush Rotational Speed	2500rpm

● AC adapter

Rating	DC24V 130mA
Dimensions	45(W) x 40(H) x 65(D)mm
Weight	0.25kg

Replacement and Optional Parts

Part No.	Name/Description
A1566	Cleaning brush A/set of 2
A1567	Cleaning brush B/set of 2
B3520	Pulley belt
B3521	Solder waste collector
B3523	Lock nut
B3517	Receptacle A
B3518	Receptacle B
B3519	Receptacle C